

MODEL 50C 1/2

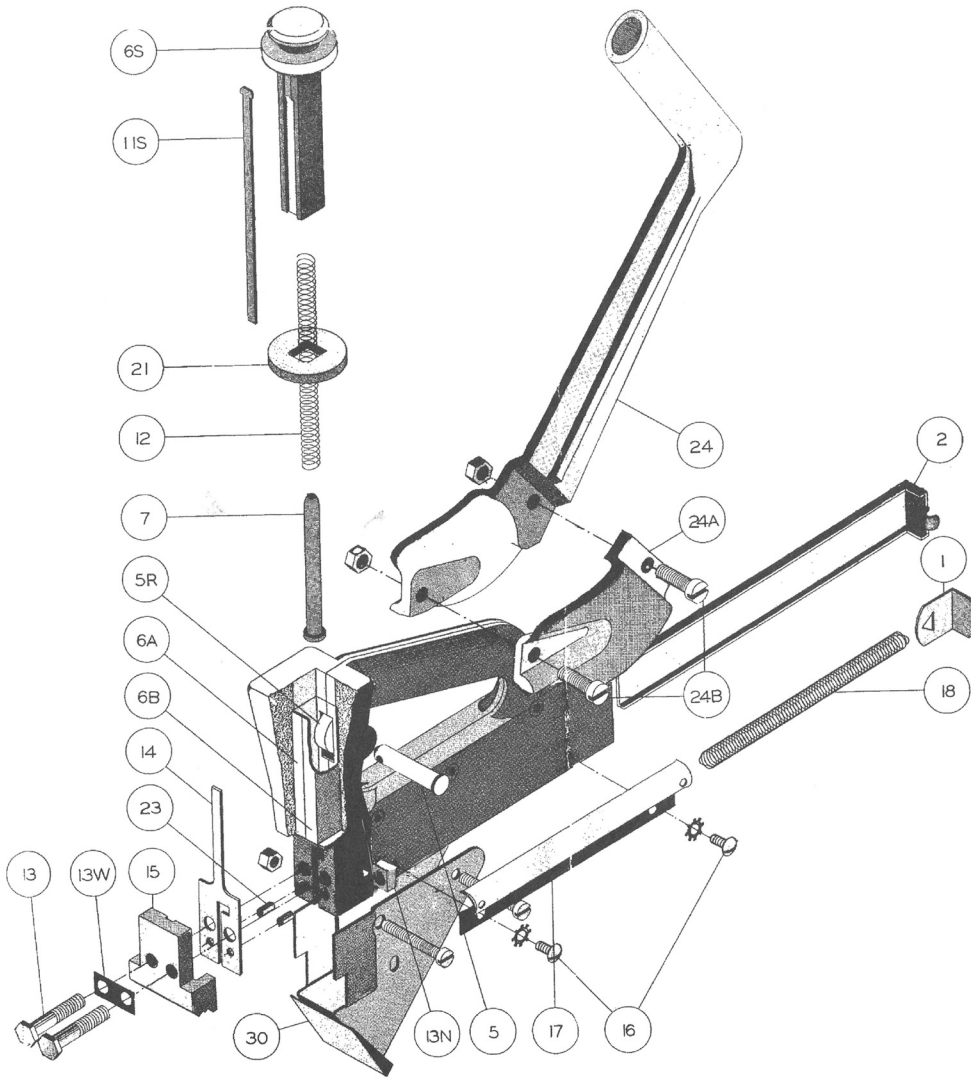

ITEM #	PART NO.	DESCRIPTION	QTY REQ'D
1	08-45-00-010	SPRING CLIP	1
2	08-45-00-020	FEEDER CHANNEL	1
5	08-50C-12-050	PLUNGER PIN & KEY ASSEMBLY	1
5R	08-50C-12-05R	PLUNGER PIN ROLLER	1
6A	08-50C-12-06A	PLUNGER LINER - RIGHT SIDE	4
6B	08-50C-12-06B	PLUNGER LINER - LEFT SIDE	4
6S	08-50C-12-06S	PLUNGER HEAD	1
7	08-50C-12-070	PLUNGER SPRING PIN	1
11S	08-50C-38-11S	DRIVING BLADE	2
12	08-50C-12-120	PLUNGER SPRING	1
13	08-50C-12-130	FOOT SCREW	1
13N	08-50C-12-13N	FOOT SCREW NUT	2
13W	08-50C-12-13W	FOOT SCREW LOCKING WASHER	2
14	08-50C-12-140	GATE	1
15	08-50C-12-150	FOOT	1
16	08-45-00-160	SPRING CONTAINER SCREW	1
17	08-45-00-170	SPRING CONTAINER	1
18	08-45-00-180	FEEDER SPRING	1
21	08-50C-12-210	RUBBER BLADE RETAINER	1
23	08-50C-12-230	DOWEL PIN	1
24	08-50C-12-240	EXTENSION HANDLE	1
24A	08-50C-12-24A	EXTENSION HANDLE BRACKET	1
24B	08-50C-12-24B	EXTENSION HANDLE SCREW & NUT	1
30	08-50C-12-300	RISER BRACKET ASSEMBLY (FOR 3/8" T&G)	1